

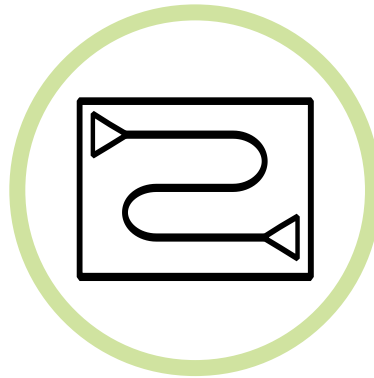

SIGMA RADIANT KONVEKTOR™



PANEL RADIATORS

TECHNICAL CATALOG



MANUFACTURERS OF HYDRONIC HEATING AND COOLING
COMMERCIAL & INDUSTRIAL



TABLE OF CONTENTS

PRODUCT OVERVIEW	3
UNIT SPECIFICATIONS & FEATURES	4
WALL-MOUNTED UNITS.....	5 - 10
PEDESTAL-MOUNTED UNITS.....	11 - 16
SELECTION PROCESS.....	18
AVERAGE WATER TEMPERATURE CORRECTION FACTORS.....	19
ALTITUDE & GLYCOL CORRECTION FACTOR	20
PRESSURE DROP	21-22



PRODUCT OVERVIEW

Sigma Radiant Konvector™ Panel Radiators are an innovative approach to hydronic architectural heating panels, combining the aesthetic beauty of a steel panel radiator with the capability of high water temperature operation. This is accomplished with a high capacity heating coil that is totally enclosed and insulated inside a simulated tubular facade.

THE PROBLEM/SOLUTION

Steel panel radiators that utilize high water temperatures are frequently misapplied in areas where the public can touch the radiator, resulting in building code violations and burns.

Across North America, most building codes do not allow temperatures above 140 °F in water pipes. Allowing for a small safety margin, entering water temperature should not be specified above 135 °F. But even when consultants specify average water temperatures of 125 °F or less (using a 20 °F delta T) building operators will often increase water temperatures on cooler days, placing the building and the owner at risk of violating codes and causing injuries.

Sigma Radiant Konvector™ Panel Radiators solve this problem, providing the architectural appearance of a steel panel radiator, while being completely safe using higher temperature water.

This is accomplished with a totally enclosed active heating element inside a simulated tubular facade. The high-capacity heating coil is insulated from the exterior, so that even carrying extremely hot water or steam, the aluminum casing does not reach temperatures above 125 °F. Of course, the unit can also operate effectively at lower water temperatures.

CONCEPT

Sigma Radiant Konvector™ (SRK) Panel Radiators are built with high capacity heating elements for both high water temperature and low pressure steam applications. The SRK concept of construction allows flexibility in heating element configurations to suit the capacity requirements of given assembly heights for wall mount or pedestal mount applications.



UNIT SPECIFICATIONS & FEATURES

The Sigma Radiant Konvector™ enclosures are comprised of oval shaped tubes arranged as a pedestal or wall-mount configurations. The tubes shall form an architectural facade and shall not carry any hot water.

Elements/Coils— Optional single tube finned E style elements shall be manufactured with nominal 3/4" Copper tube expanded into the Aluminum fins and shall be rated for 220 psi working pressure. The multi-tube CV style coils shall be manufactured with 1/2" OD Copper tubes expanded into the Aluminum fins and shall be rated for a maximum working pressure of 150 psig. Both the single tube elements and multi-tube coils come with sweat connections.

Finish — Enclosure shall be provided with a powder coat finish, with all painted surfaces cleaned and phosphatized before powder coating. Standard colour options are available to choose from. Custom colour matches are also available.

Field mounting — floor-mounted units will be supplied with pedestals; wall-mounted units will be supplied with continuous joggle strip with supporting wall mount brackets.

Levelling — Contractor to ensure that the units are installed level and appropriate fasteners utilized for respective mounting surfaces.

Optional overlapping accessories — such as trims, corners, and end-caps to be provided to suit site conditions.



SRK

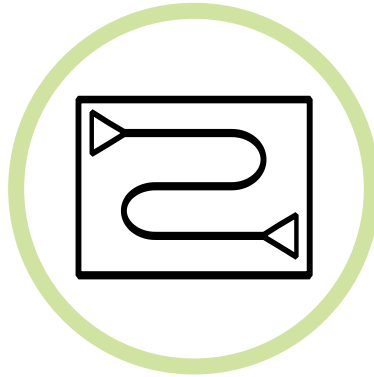

WALL-MOUNT





WALL MOUNT SRK UNITS

TYPE E24

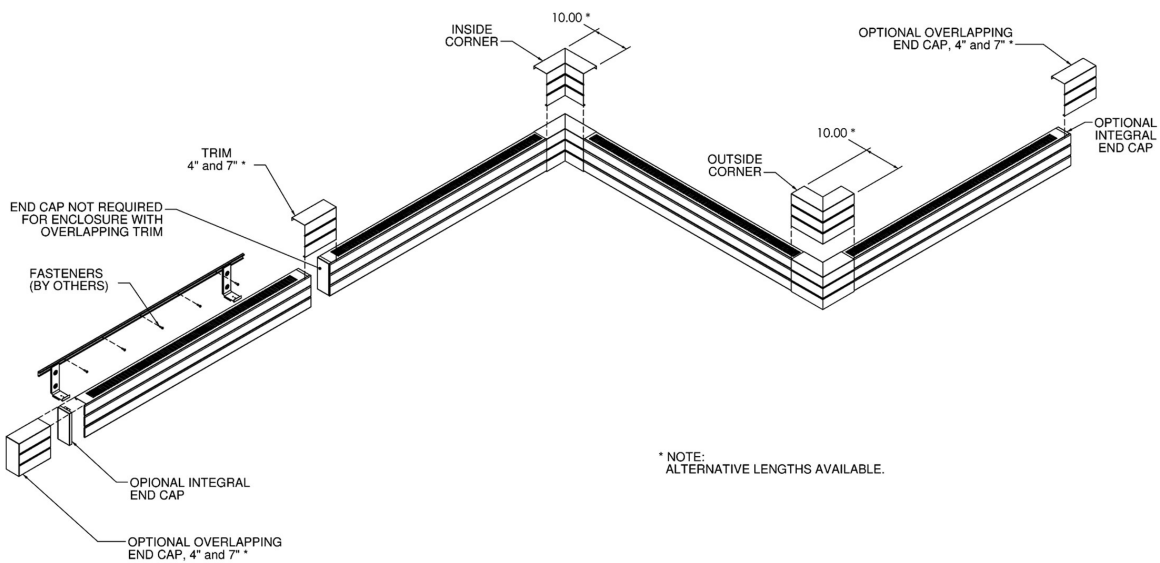
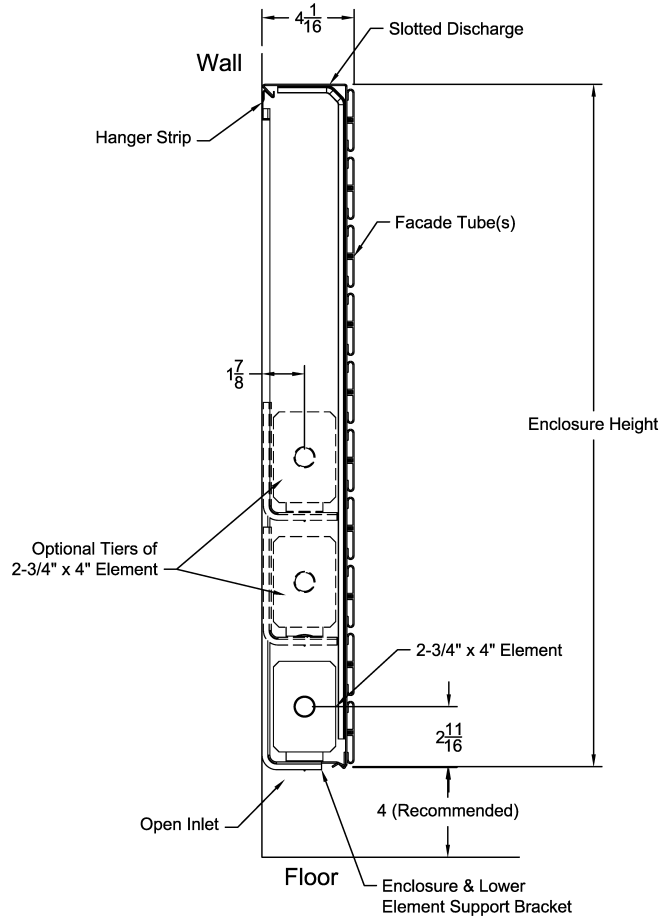



WALL MOUNT SRK

ELEMENT MODEL SERIES E24

Wall Mounted Enclosure				BTU/Ft @ AWT, 65°F EAT, 3 FPS						
Model	Height	Width	E24 element	100°F	110°F	120°F	130°F	140°F	150°F	160°F
SRK-2	5-13/16"	4-1/16"	1 row	220	293	381	483	586	659	776
SRK-3	8-13/16"	4-1/16"	1 row	230	307	399	506	613	690	812
SRK-4	11-13/16"	4-1/16"	1 row	240	321	417	529	641	721	849
			2 row	328	438	569	722	875	984	1159
SRK-5	14-13/16"	4-1/16"	1 row	251	334	435	552	668	752	886
			2 row	342	456	592	752	911	1025	1207
SRK-6	17-13/16"	4-1/16"	1 row	261	348	453	574	696	783	922
			2 row	355	474	616	781	947	1065	1254
			3 row	409	546	709	900	1091	1227	1445
SRK-7	20-13/16"	4-1/16"	1 row	270	360	468	594	720	810	954
			2 row	369	492	639	811	983	1106	1302
			3 row	425	566	736	934	1132	1274	1500
SRK-8	23-13/16"	4-1/16"	1 row	278	371	483	612	742	835	983
			2 row	382	510	662	841	1019	1146	1350
			3 row	440	587	763	968	1174	1320	1555
SRK-9	26-13/16"	4-1/16"	1 row	287	382	497	631	764	860	1013
			2 row	396	529	687	872	1057	1189	1400
			3 row	457	609	792	1005	1218	1370	1613
SRK-10	29-13/16"	4-1/16"	1 row	295	393	511	649	786	884	1041
			2 row	410	547	711	902	1093	1229	1448
			3 row	472	630	818	1039	1259	1416	1668
SRK-11	32-13/16"	4-1/16"	1 row	303	404	525	666	808	909	1070
			2 row	423	565	734	931	1129	1270	1496
			3 row	488	650	845	1073	1300	1463	1723
SRK-12	35-13/16"	4-1/16"	1 row	311	416	539	684	829	933	1099
			2 row	437	583	757	961	1165	1310	1543
			3 row	503	671	873	1107	1342	1510	1778

Note: Correction factors to be applied against the 160F BTU/Ft capacity data. Refer to pages 18 - 21.



WALL MOUNT SRK

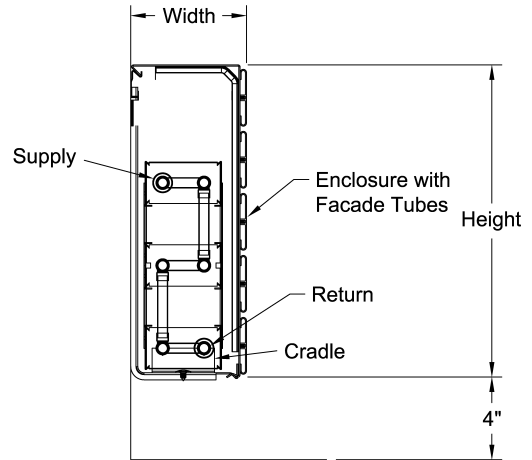
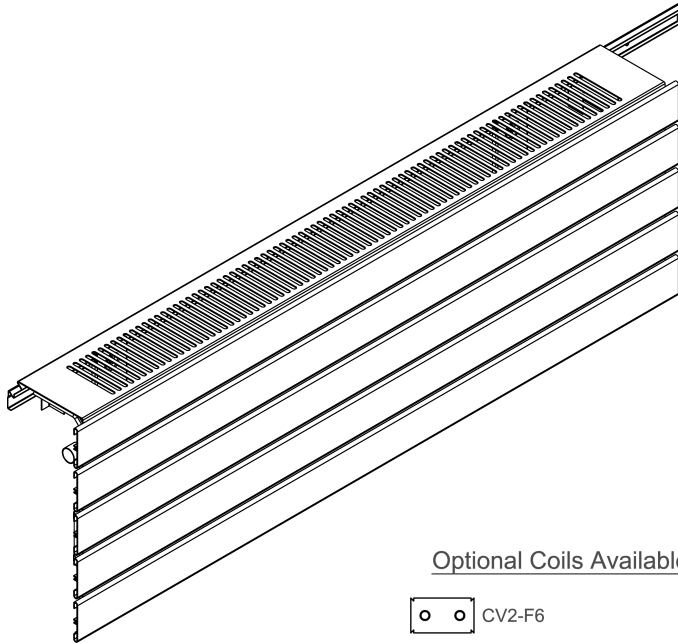

Model configuration SRK-A.0-W-5.6-5 shown with CV2-3H-4CC Coil.

Optional Coils Available

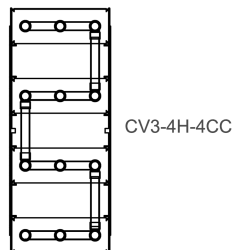
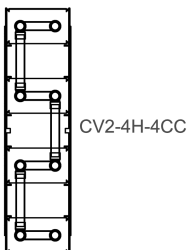
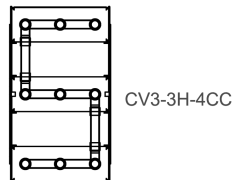
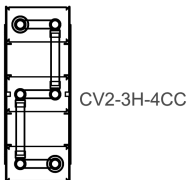
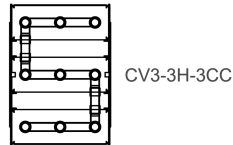
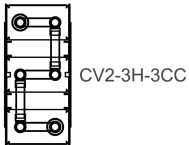
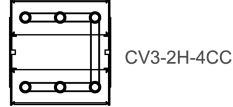
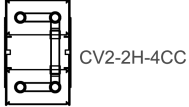
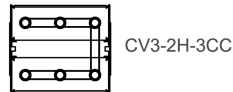
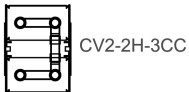



WALL MOUNT SRK

COIL MODEL SERIES CV2

Wall Mounted Enclosure			BTU/Ft @ AWT, 65°F EAT, 3 FPS							
Model	Height	Width	Coil	100°F	110°F	120°F	130°F	140°F	150°F	160°F
SRK-2	5-13/16"	5-5/8"	CV2-F6	176	234	304	386	467	526	619
			CV2-2H-2CC	229	305	396	503	609	686	807
SRK-3	8-13/16"	5-5/8"	CV2-F6	183	244	318	403	488	549	647
			CV2-2H-2CC	240	319	415	527	638	718	846
SRK-4	11-13/16"	5-5/8"	CV2-F6	192	255	332	421	510	574	676
			CV2-2H-4CC	275	367	477	605	733	825	972
			CV2-3H-3CC	309	412	535	679	823	926	1091
SRK-5	14-13/16"	5-5/8"	CV2-F6	200	266	346	439	532	599	705
			CV2-2H-4CC	287	382	496	630	763	859	1011
			CV2-3H-4CC	337	449	584	741	898	1011	1190
			CV2-4H-3CC	346	461	599	760	921	1037	1221
SRK-6	17-13/16"	5-5/8"	CV2-F6	208	277	361	458	554	624	735
			CV2-2H-4CC	299	398	517	656	795	895	1054
			CV2-3H-4CC	351	468	608	772	935	1052	1239
			CV2-4H-4CC	377	502	653	829	1004	1130	1331
SRK-7	20-13/16"	5-5/8"	CV2-F6	216	287	374	474	574	646	761
			CV2-2H-4CC	309	412	535	679	823	926	1091
			CV2-3H-4CC	363	484	629	798	967	1088	1282
			CV2-4H-4CC	390	520	676	858	1040	1170	1378
SRK-8	23-13/16"	5-5/8"	CV2-F6	222	295	384	487	590	664	782
			CV2-2H-4CC	318	424	551	699	847	953	1123
			CV2-3H-4CC	374	498	648	822	996	1121	1320
			CV2-4H-4CC	402	535	696	883	1070	1204	1418
SRK-9	26-13/16"	5-5/8"	CV2-F6	228	304	396	502	608	684	806
			CV2-2H-4CC	328	437	569	722	874	984	1159
			CV2-3H-4CC	386	514	669	849	1028	1157	1363
			CV2-4H-4CC	414	552	718	911	1104	1242	1463
SRK-10	29-13/16"	5-5/8"	CV2-F6	235	313	407	517	626	705	830
			CV2-2H-4CC	337	449	584	741	898	1011	1190
			CV2-3H-4CC	396	528	687	872	1056	1188	1400
			CV2-4H-4CC	426	568	738	937	1135	1277	1504
SRK-11	32-13/16"	5-5/8"	CV2-F6	242	322	418	531	643	724	852
			CV2-2H-4CC	347	462	600	762	923	1039	1223
			CV2-3H-4CC	407	543	706	896	1085	1221	1438
			CV2-4H-4CC	438	583	758	962	1166	1312	1545
SRK-12	35-13/16"	5-5/8"	CV2-F6	248	330	429	545	660	743	875
			CV2-2H-4CC	356	474	616	782	947	1066	1255
			CV2-3H-4CC	418	557	725	920	1114	1254	1477
			CV2-4H-4CC	449	599	779	988	1197	1347	1587

Note: Correction factors to be applied against the 160F BTU/Ft capacity data. Refer to pages 18 - 21.



WALL MOUNT SRK

COIL MODEL SERIES CV3

Wall Mounted Enclosure				BTU/Ft @ AWT, 65°F EAT, 3 FPS						
Model	Height	Width	Coil	100°F	110°F	120°F	130°F	140°F	150°F	160°F
SRK-2	5-13/16"	7-5/8"	CV3-2H-2CC	360	480	624	792	960	1080	1272
SRK-3	8-13/16"	7-5/8"	CV3-2H-2CC	377	503	654	830	1005	1131	1332
SRK-4	11-13/16"	7-5/8"	CV3-2H-4CC	433	577	751	953	1154	1299	1530
			CV3-3H-3CC	487	649	844	1071	1297	1460	1719
SRK-5	14-13/16"	7-5/8"	CV3-2H-4CC	452	602	783	994	1204	1355	1596
			CV3-3H-4CC	531	708	921	1169	1416	1593	1877
			CV3-4H-3CC	537	716	931	1181	1431	1610	1897
SRK-6	17-13/16"	7-5/8"	CV3-2H-4CC	470	627	815	1034	1253	1410	1661
			CV3-3H-4CC	553	737	959	1217	1474	1659	1954
			CV3-4H-4CC	585	780	1014	1287	1560	1755	2067
SRK-7	20-13/16"	7-5/8"	CV3-2H-4CC	487	649	844	1071	1298	1461	1720
			CV3-3H-4CC	573	763	992	1259	1526	1717	2022
			CV3-4H-4CC	606	808	1050	1333	1615	1817	2140
SRK-8	23-13/16"	7-5/8"	CV3-2H-4CC	501	668	869	1103	1336	1503	1771
			CV3-3H-4CC	590	786	1022	1297	1571	1768	2082
			CV3-4H-4CC	624	832	1081	1372	1663	1871	2204
SRK-9	26-13/16"	7-5/8"	CV3-2H-4CC	517	689	896	1137	1377	1550	1825
			CV3-3H-4CC	608	810	1053	1337	1620	1823	2147
			CV3-4H-4CC	644	858	1115	1415	1715	1930	2273
SRK-10	29-13/16"	7-5/8"	CV3-2H-4CC	531	708	921	1169	1416	1593	1877
			CV3-3H-4CC	625	833	1083	1375	1666	1875	2208
			CV3-4H-4CC	662	882	1146	1455	1763	1984	2336
SRK-11	32-13/16"	7-5/8"	CV3-2H-4CC	546	728	946	1201	1455	1637	1928
			CV3-3H-4CC	642	856	1113	1413	1712	1926	2269
			CV3-4H-4CC	680	906	1178	1495	1812	2039	2401
SRK-12	35-13/16"	7-5/8"	CV3-2H-4CC	561	747	972	1233	1494	1681	1980
			CV3-3H-4CC	659	879	1143	1450	1757	1977	2329
			CV3-4H-4CC	698	930	1209	1535	1860	2093	2465

Note: Correction factors to be applied against the 160F BTU/Ft capacity data. Refer to pages 18 - 21.



SRK

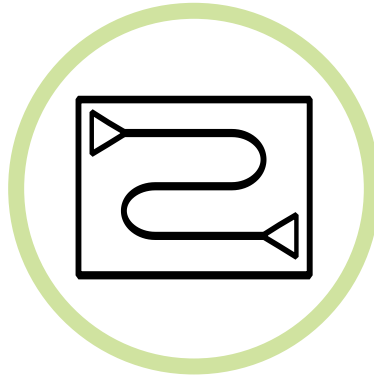

PEDESTAL-MOUNT

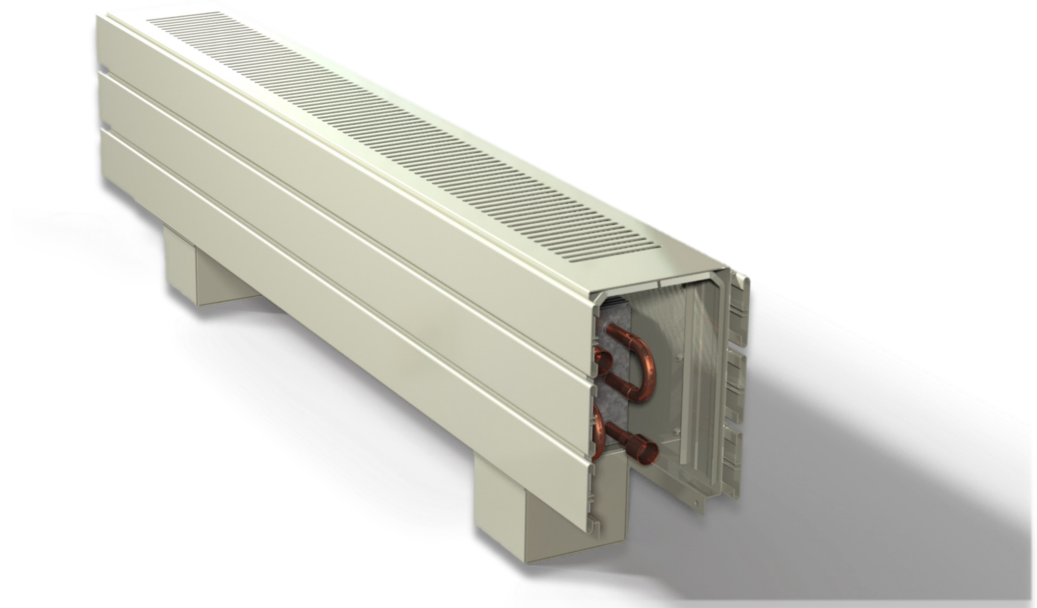



PEDESTAL MOUNT SRK

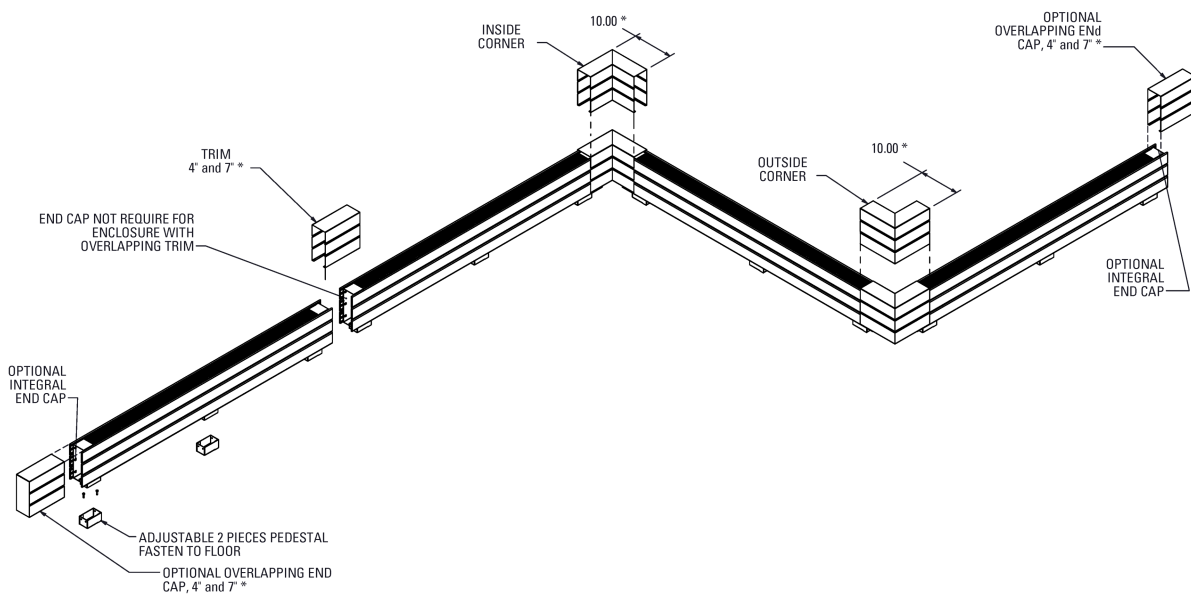
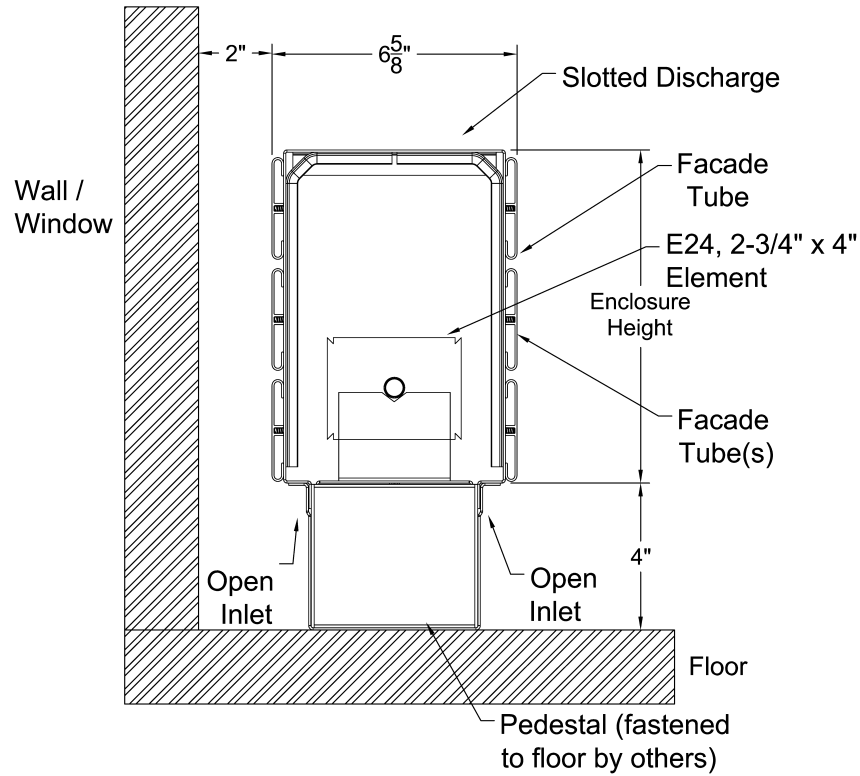



PEDESTAL MOUNT SRK

ELEMENT MODEL SERIES E24

Pedestal Free Standing Enclosure			BTU/Ft @ AWT, 65°F EAT, 3 FPS							
Model	Height	Width	E24 element	100°F	110°F	120°F	130°F	140°F	150°F	160°F
SRK-2	5-13/16"	6-5/8"	1 row	206	275	357	453	549	618	727
SRK-3	8-13/16"	6-5/8"	1 row	220	293	381	483	585	658	775
SRK-4	11-13/16"	6-5/8"	1 row	234	312	405	514	623	701	825
			2 row	303	403	524	665	806	907	1068
SRK-5	14-13/16"	6-5/8"	1 row	248	331	430	546	662	774	877
			2 row	345	460	597	758	919	1034	1217
SRK-6	17-13/16"	6-5/8"	1 row	263	351	456	579	701	789	929
			2 row	387	516	671	851	1032	1161	1367
			3 row	445	593	772	979	1187	1335	1572

Note: Correction factors to be applied against the 160F BTU/Ft capacity data. Refer to pages 18 - 21.



PEDESTAL MOUNT SRK

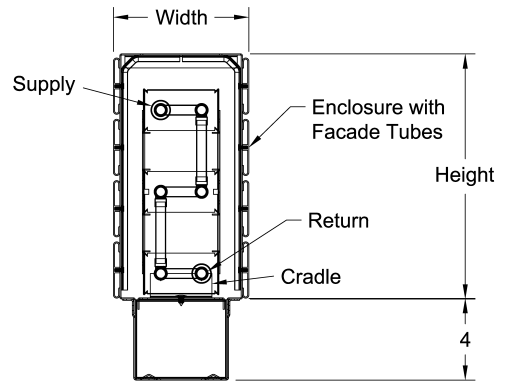
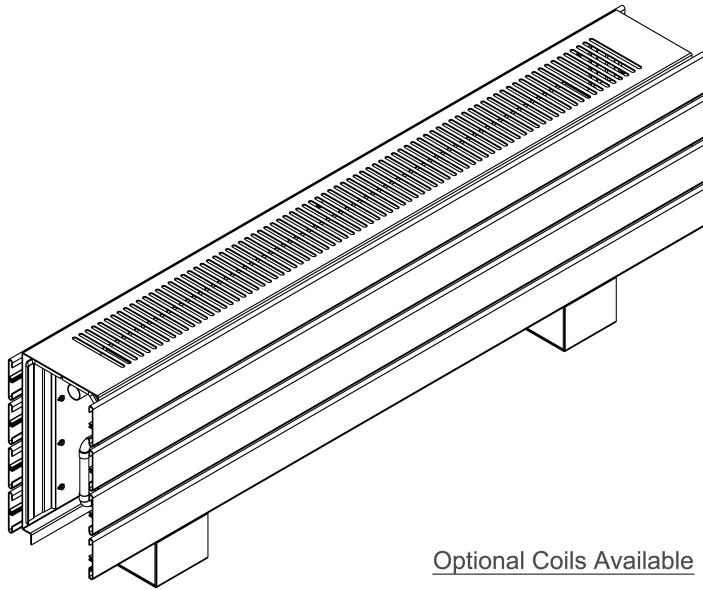

Model configuration SRK-A.0-P-6.6-4 shown with CV2-3H-4CC Coil.

Optional Coils Available

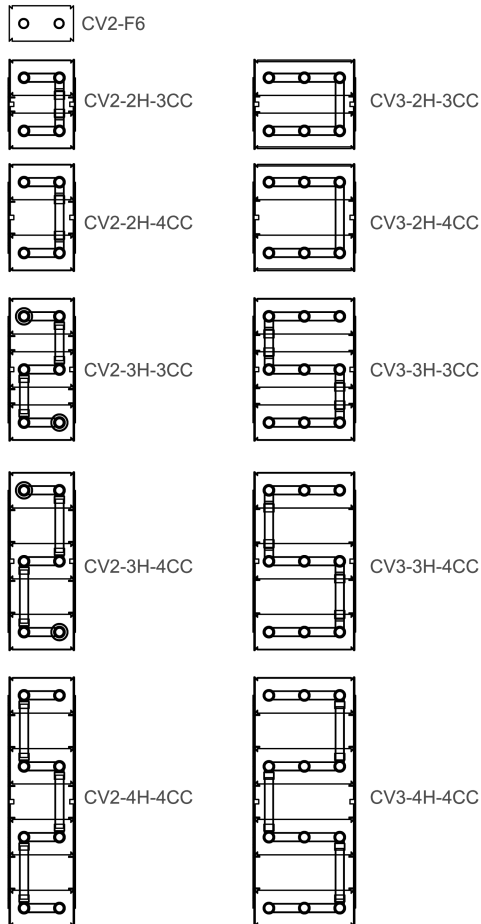



PEDESTAL MOUNT SRK

COIL MODEL SERIES CV2

Pedestal Free Standing Enclosure				BTU/Ft @ AWT, 65°F EAT, 3 FPS						
Model	Height	Pedestal	Coil	100°F	110°F	120°F	130°F	140°F	150°F	160°F
SRK-2	5-13/16"	6-5/8"	CV2-F6	176	234	304	386	467	526	619
			CV2-2H-2CC	229	305	396	503	609	686	807
SRK-3	8-13/16"	6-5/8"	CV2-F6	183	244	318	403	488	549	647
			CV2-2H-2CC	240	319	415	527	638	718	846
			CV2-2H-4CC	263	350	455	578	700	788	928
SRK-4	11-13/16"	6-5/8"	CV2-F6	192	255	332	421	510	574	676
			CV2-2H-4CC	275	367	477	605	733	825	972
			CV2-3H-3CC	309	412	535	679	823	926	1091
			CV2-3H-4CC	323	431	560	711	861	969	1141
SRK-5	14-13/16"	6-5/8"	CV2-F6	200	266	346	439	532	599	705
			CV2-2H-4CC	287	382	496	630	763	859	1011
			CV2-3H-4CC	337	449	584	741	898	1011	1190
			CV2-4H-3CC	346	461	599	760	921	1037	1221
SRK-6	17-13/16"	6-5/8"	CV2-F6	208	277	361	458	554	624	735
			CV2-2H-4CC	299	398	517	656	795	895	1054
			CV2-3H-4CC	351	468	608	772	935	1052	1239
			CV2-4H-4CC	377	502	653	829	1004	1130	1331
SRK-7	20-13/16"	6-5/8"	CV2-F6	216	287	374	474	574	646	761
			CV2-2H-4CC	309	412	535	679	823	926	1091
			CV2-3H-4CC	363	484	629	798	967	1088	1282
			CV2-4H-4CC	390	520	676	858	1040	1170	1378
SRK-8	23-13/16"	6-5/8"	CV2-F6	222	295	384	487	590	664	782
			CV2-2H-4CC	318	424	551	699	847	953	1123
			CV2-3H-4CC	374	498	648	822	996	1121	1320
			CV2-4H-4CC	402	535	696	883	1070	1204	1418
SRK-9	26-13/16"	6-5/8"	CV2-F6	228	304	396	502	608	684	806
			CV2-2H-4CC	328	437	569	722	874	984	1159
			CV2-3H-4CC	386	514	669	849	1028	1157	1363
			CV2-4H-4CC	414	552	718	911	1104	1242	1463
SRK-10	29-13/16"	6-5/8"	CV2-F6	235	313	407	517	626	705	830
			CV2-2H-4CC	337	449	584	741	898	1011	1190
			CV2-3H-4CC	396	528	687	872	1056	1188	1400
			CV2-4H-4CC	426	568	738	937	1135	1277	1504
SRK-11	32-13/16"	6-5/8"	CV2-F6	242	322	418	531	643	724	852
			CV2-2H-4CC	347	462	600	762	923	1039	1223
			CV2-3H-4CC	407	543	706	896	1085	1221	1438
			CV2-4H-4CC	438	583	758	962	1166	1312	1545
SRK-12	35-13/16"	6-5/8"	CV2-F6	248	330	429	545	660	743	875
			CV2-2H-4CC	356	474	616	782	947	1066	1255
			CV2-3H-4CC	418	557	725	920	1114	1254	1477
			CV2-4H-4CC	449	599	779	988	1197	1347	1587

Note: Correction factors to be applied against the 160F BTU/Ft capacity data. Refer to pages 18 - 21.



PEDESTAL MOUNT SRK

COIL MODEL SERIES CV3

Pedestal Free Standing Enclosure				BTU/Ft @ AWT, 65°F EAT, 3 FPS						
Model	Height	Pedestal	Coil	100°F	110°F	120°F	130°F	140°F	150°F	160°F
SRK-2	5-13/16"	8-5/8"	CV3-2H-2CC	360	480	624	792	960	1080	1272
SRK-3	8-13/16"	8-5/8"	CV3-2H-2CC	377	503	654	830	1005	1131	1332
			CV3-2H-4CC	414	552	718	911	1104	1242	1463
SRK-4	11-13/16"	8-5/8"	CV3-2H-4CC	433	577	751	953	1154	1299	1530
			CV3-3H-3CC	487	649	844	1071	1297	1460	1719
			CV3-3H-4CC	510	679	883	1121	1358	1528	1800
SRK-5	14-13/16"	8-5/8"	CV3-2H-4CC	452	602	783	994	1204	1355	1596
			CV3-3H-4CC	531	708	921	1169	1416	1593	1877
			CV3-4H-3CC	537	716	931	1181	1431	1610	1897
SRK-6	17-13/16"	8-5/8"	CV3-2H-4CC	470	627	815	1034	1253	1410	1661
			CV3-3H-4CC	553	737	959	1217	1474	1659	1954
			CV3-4H-4CC	585	780	1014	1287	1560	1755	2067
SRK-7	20-13/16"	8-5/8"	CV3-2H-4CC	487	649	844	1071	1298	1461	1720
			CV3-3H-4CC	573	763	992	1259	1526	1717	2022
			CV3-4H-4CC	606	808	1050	1333	1615	1817	2140
SRK-8	23-13/16"	8-5/8"	CV3-2H-4CC	501	668	869	1103	1336	1503	1771
			CV3-3H-4CC	590	786	1022	1297	1571	1768	2082
			CV3-4H-4CC	624	832	1081	1372	1663	1871	2204
SRK-9	26-13/16"	8-5/8"	CV3-2H-4CC	517	689	896	1137	1377	1550	1825
			CV3-3H-4CC	608	810	1053	1337	1620	1823	2147
			CV3-4H-4CC	644	858	1115	1415	1715	1930	2273
SRK-10	29-13/16"	8-5/8"	CV3-2H-4CC	531	708	921	1169	1416	1593	1877
			CV3-3H-4CC	625	833	1083	1375	1666	1875	2208
			CV3-4H-4CC	662	882	1146	1455	1763	1984	2336
SRK-11	32-13/16"	8-5/8"	CV3-2H-4CC	546	728	946	1201	1455	1637	1928
			CV3-3H-4CC	642	856	1113	1413	1712	1926	2269
			CV3-4H-4CC	680	906	1178	1495	1812	2039	2401
SRK-12	35-13/16"	8-5/8"	CV3-2H-4CC	561	747	972	1233	1494	1681	1980
			CV3-3H-4CC	659	879	1143	1450	1757	1977	2329
			CV3-4H-4CC	698	930	1209	1535	1860	2093	2465

Note: Correction factors to be applied against the 160F BTU/Ft capacity data. Refer to pages 18 - 21.



SRK

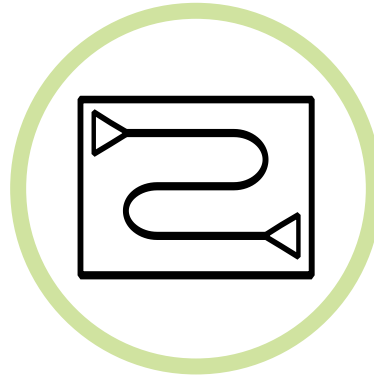

SELECTION PROCESS & CORRECTION FACTORS



SRK SELECTION

Parameters

- Entering water temperature: 140F EWT
- Delta T: 20F
- Entering air temperature = 65F EAT (Industry Standard)
- Calculated heat loss for the given room that includes margin of safety: 7000 Btu/hr
- Space dimension wall-to-wall length: 10 feet
- Height restrictions 20 inches floor to sill height
- Mounting type wall mount

Selection 1:

- To determine the SRK enclosure height, we recommend a clearance from the floor to the bottom of the enclosure to be 4". Thus:
 $(20" \text{ height limitation}) - (4" \text{ clearance at floor}) = 16" \text{ nominal enclosure height}$
- Review of pages 8, 9, or 10 for wall mount enclosure heights. The SRK-5 would be a good choice having a height of 14-13/16".
- To determine the coil length and then target BTU/Ft heat output, a clearance for field plumbing/valves, we recommend a minimum of 1.5 feet. Thus:
 $(10 \text{ foot wall-to-wall length}) - (1.5 \text{ foot clearance}) = 8.5 \text{ foot coil length}$
 $(7000 \text{ Btu/hr heat loss}) / (8.5 \text{ foot coil length}) = 824 \text{ BTU/Ft ideal target}$
- To determine the AWT (average water Temperature), determine as follows:
 $140\text{F EWT} - (20\text{F Delta T} / 2) = 130\text{F AWT}$
- Again, refer to page 8, 9, 10 for performance data. With review of SRK-5 with E24 element, CV2 coils and CV3 coils, the best coil model is CV3-2H-4CC, having 994 BTU/Ft, as follows:
 $7000 \text{ BTU} / 994 \text{ Btu/Ft} = 7.042 \text{ Ft}$
Thus, 7 Ft x 994 BTU/Ft = 6958 BTU

Conclusion:

- Model SRK: SRK-W-5-CV3-2H-4CC, with 7 foot coil.

Selection 2

- Same conditions as Selection 1 above, but with 30% PG (propylene Glycol).
- Refer to page 19 for glycol correction factors, 0.96 noted for 30% PG.
- Apply the glycol correction factor to the ideal target capacity as follows:
 $(824 \text{ BTU/Ft ideal target with 30\% PG}) / 0.96 \text{ correction factor} = 858 \text{ BTU/Ft (with 100\% water)}$
- Again, refer to page 8, 9, 10 for performance data. With review of SRK-5 with E24 element, CV2 coils and CV3 coils. Once again, the best coil model is CV3-2H-4CC, having 994 BTU/Ft with 100% water. Now apply the glycol correction factor:
 $994 \text{ BTU/Ft} * 0.96 \text{ correction factor} = 954 \text{ BTU/Ft}$
- $7000 \text{ BTU} / 954 \text{ Btu/ft} = 7.33 \text{ Ft}$
Thus, 7.5 Ft x 954 = 7155 Btu/ft

Conclusion:

- Model SRK: SRK-W-5-CV3-2H-4CC, with 7.5 foot coil.



CORRECTION FACTORS

CORRECTION FACTORS FOR VARIOUS WATER & AIR TEMPERATURES

Average Water Temperature	Entering Air Temperature										
	45 °F	50 °F	55 °F	60 °F	65 °F	68 °F	70 °F	72 °F	75 °F	80 °F	85 °F
90	0.358	0.301	0.245	0.226	0.207	0.151	0.113				
95	0.415	0.358	0.301	0.283	0.245	0.207	0.169				
100	0.471	0.415	0.358	0.32	0.283	0.245	0.207	0.188	0.151	0.113	
105	0.528	0.471	0.415	0.377	0.339	0.301	0.264	0.245	0.207	0.169	
110	0.584	0.528	0.471	0.434	0.377	0.339	0.301	0.283	0.245	0.207	0.151
115	0.66	0.603	0.528	0.49	0.434	0.396	0.358	0.339	0.301	0.264	0.207
120	0.717	0.66	0.584	0.547	0.49	0.434	0.396	0.396	0.358	0.301	0.245
125	0.792	0.735	0.66	0.622	0.566	0.509	0.471	0.452	0.415	0.358	0.301
130	0.849	0.792	0.717	0.679	0.622	0.566	0.528	0.509	0.471	0.396	0.358
135	0.924	0.867	0.792	0.754	0.698	0.641	0.584	0.566	0.528	0.471	0.415
140	1	0.924	0.849	0.811	0.754	0.698	0.641	0.622	0.584	0.528	0.471
145	1.075	1	0.924	0.867	0.811	0.754	0.717	0.698	0.66	0.584	0.528
150	1.151	1.075	1	0.924	0.849	0.811	0.773	0.754	0.717	0.641	0.584
155	1.226	1.151	1.075	1	0.924	0.886	0.849	0.83	0.792	0.717	0.66
160	1.301	1.226	1.151	1.075	1	0.962	0.924	0.905	0.849	0.773	0.717
165	1.377	1.301	1.226	1.151	1.075	1.037	1	0.981	0.924	0.849	0.792
170	1.452	1.377	1.301	1.226	1.151	1.113	1.075	1.056	1	0.924	0.849
175	1.547	1.471	1.377	1.301	1.226	1.188	1.151	1.132	1.075	1	0.924
180	1.622	1.547	1.452	1.377	1.301	1.264	1.226	1.207	1.151	1.075	1

Note: Correction factors to be applied against the 160F BTU/Ft capacity data.



ALTITUDE CORRECTION FACTORS

Altitude	Non-Ferrous (Copper Alum.)
Sea Level	1
1,000 Ft	0.969
2,000 Ft	0.938
3,000 Ft	0.908
4,000 Ft	0.878
5,000 Ft	0.85
6,000 Ft	0.822
7,000 Ft	0.795
8,000 Ft	0.768
9,000 Ft	0.743
10,000 Ft	0.718
15,000 Ft	0.603
20,000 Ft	0.502

GLYCOL CORRECTION FACTORS

Solution	Ethylene Glycol	Propylene Glycol
0.2	0.95	0.98
0.3	0.91	0.96
0.4	0.88	0.93
0.5	0.84	0.9
Pressure Drop	1.23	1.23



PRESSURE DROP CHART

COIL TYPE CV2

CV2 Coil Model - Feet of WPD per foot of coil					
GPM	Velocity Ft/Sec	Length of Coil (ft.)			
		CV2-1H	CV2-2H	CV2-3H	CV2-4H
0.27	0.5	0.010	0.020	0.030	0.040
0.53	1	0.030	0.060	0.090	0.120
0.79	1.5	0.065	0.130	0.195	0.260
1.06	2	0.105	0.210	0.315	0.420
1.33	2.5	0.155	0.310	0.465	0.620
1.6	3	0.215	0.430	0.645	0.860

PRESSURE DROP CHART

COIL TYPE CV3

CV3 Coil Model - Feet of WPD per foot of coil					
GPM	Velocity Ft/Sec	Length of Coil (ft.)			
		CV3-1H	CV3-2H	CV3-3H	CV3-4H
0.27	0.5	0.015	0.030	0.045	0.060
0.53	1	0.045	0.090	0.135	0.180
0.79	1.5	0.098	0.195	0.293	0.390
1.06	2	0.016	0.032	0.047	0.063
1.33	2.5	0.233	0.465	0.698	0.930
1.6	3	0.323	0.645	0.968	1.290



PRESSURE DROP

TYPE E24

E24 Element Model - Feet of WPD per foot of element		
		Length of Coil (ft.)
GPM	Velocity Ft/Sec	E24
0.6	0.5	0.0041
1.67	1	0.010
2.5	1.5	0.021
3.34	2	0.032
4.16	2.5	0.053
5	3	0.063